



American Made

PERFECTO PRODUCTS, INC

Plumbing Specialty Tools

PERFECTO Hydrostatic Test Pump

It is imperative that clean water be used in testing. Foreign matter under the valve seats will render the pump inoperative.

The valves may be replaced by removing the 3/4" x 1/2" bushings from the inlet and outlet of the pump. When installing new check valves, be sure that the brass faces of *both* the valves are facing toward the inlet of the pump.

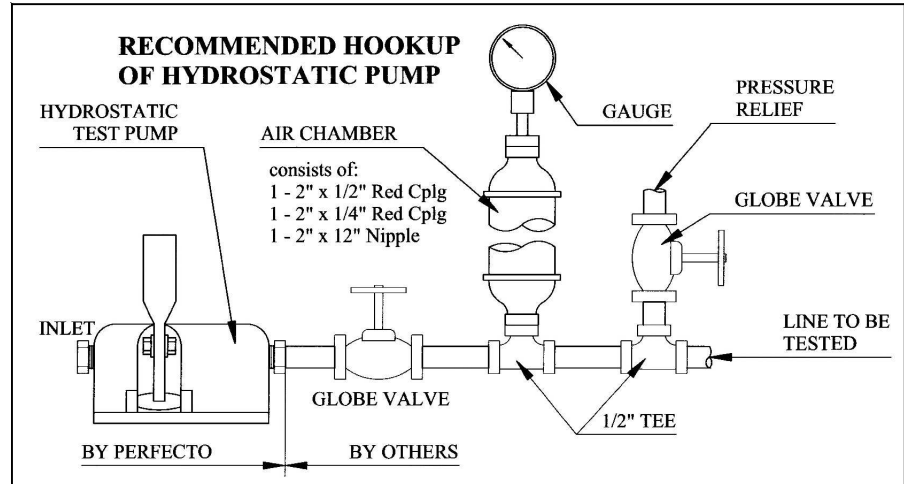

Model P1000

Designed for use in testing pipe lines, radiant heating systems, valves bodies, and pressure vessels. Body is of 356 Aluminum, piston is 416 stainless steel. Check valves are a special poppet valve that functions under almost any conditions.

Pressure Range	Weight	Inlet	Outlet	Cylinder	Stroke	Displacement
0-1000 psig	7 lbs	1/2" FPT	1/2" FPT	7/8" dia.	2"	1.37 in ³

Operating Instructions:

1. Fill the system to be tested with water directly through the pump, using the pressure of the water supply. Pull the pump handle back to let the cylinder fill with water. The inlet and outlet valves within the body of the pump will automatically open to allow flow. The manually operated isolation valve on the downstream side of the pump must be open at this point. When the system reaches the same pressure as the water supply, the inlet valve inside the pump body will automatically close.
2. Always maintain water source pressure to the inlet to prevent air from entering the pump.
3. BLEED ALL AIR FROM THE SYSTEM TO BE TESTED.
4. Pump the system up to the desired pressure, then close the manual operated isolation valve.
5. Upon completion of the test, relieve pressure in the system by opening the air bleed valves.
6. OPEN MANUALLY OPERATED ISOLATION VALVE TO RELIEVE PRESSURE ON THE INTERNAL OUTLET POPPET VALVE.
7. Maintain pressure only long enough to test the system.
8. Keep from freezing if water is left in the pump.
9. Keep dirt and debris out of the ports of the pump.
10. PUMP WITH SMOOTH EVEN STROKES! POPPET VALVES MAY BLOW OUT IF STROKES ARE HARSH AND ABRUPT.

HYDROSTATIC TEST PUMP
PARTS LIST AND ASSEMBLY PERFECTO MODELS P-1000, P-2000 AND P-1000D

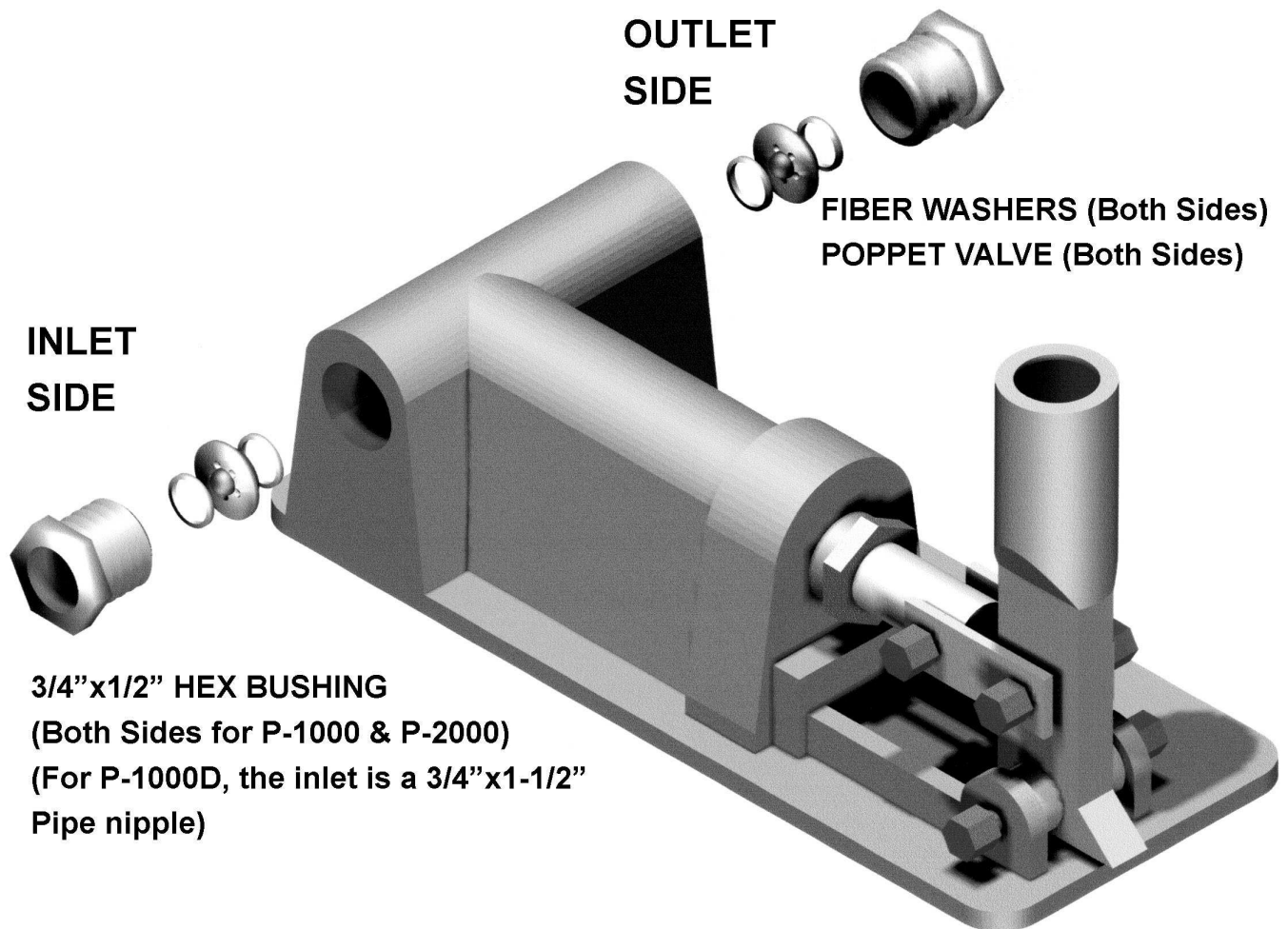

NOTE! TIGHTEN BUSHINGS ONLY UNTIL LEAKAGE STOPS. ANY FURTHER TIGHTENING WILL SQUASH THE WASHERS AND PREVENT THE POPPET VALVES FROM WORKING